

DC Motors

Teleoperations of
Aerospace
Payload Systems
Week 03



Motor Types:

Motors come in all sorts of varieties. The types that are most commonly used in robotics are Direct Current (DC) and usually operate as either **freely-rotating** motors or as **servo** (positioning) motors. Other types, such as **AC motors**, require an AC power source (i.e., plug it into the wall) which isn't suited to mobile robots. **Stepper motors** are (technically) DC motors, and have many important applications in robotics, especially when fine motion control is needed. However their use is more complicated.

Motors & Gear Trains:

Most DC motors (except perhaps, stepper motors) rotate at relatively high speeds (in the 10's of thousands of rpm). In robotics, this nearly always means that we need to use a **gear train** to convert these rotational speeds into a more useful range. Sometimes these gear trains are built right into the motor, sometimes it is coupled to the motor externally.

Motor Characteristics:

Motors are usually selected based on some key parameters. Their typical units are included).

- **Rotation Speed** (revolutions per minute, rpm). How quickly the shaft of the motor turns.
- **Rotation Torque** (Newton·meters). A measure of the rotational “strength” or “force” of the motor.
- **Current Drawn** (Amperes). The amount of charge being drawn by the motor per second.
- **Operating Voltage** (Volts). The magnitude of the driving motivation turning the motor.
- **Efficiency (%)**. A measure of what fraction of the electrical power is converted into mechanical power.

Once the basic vehicle design has been evaluated, you should have some sort of idea of the torque that will be necessary to turn the wheels and move the vehicle.

With the torque requirement, we can then go about evaluating and selecting a DC motor that will satisfy this requirement best.

DC Motor Basics:

The fundamental principles behind the operation of a motor is usually covered in the electromagnetics section of an introductory physics course.

In short, when a current-carrying wire is placed in a magnetic field, a force is created on the wire, causing it to move (accelerate) in a direction that is perpendicular to both the wire (i.e., the current) and the magnetic flux field. This is known as the **Lorentz Force Law**. When the wires and magnets are arranged in an ingenious way, it produces a continuous rotational motion— i.e., a motor.

$$\mathbf{F} = L (\mathbf{i} \times \mathbf{B})$$

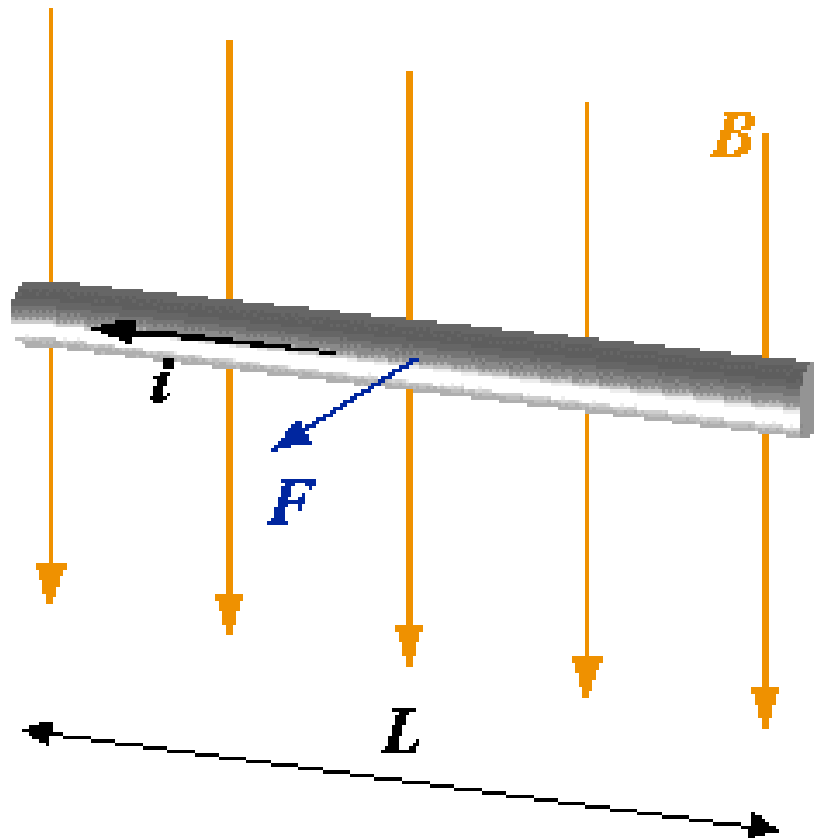

\mathbf{F} = force, newtons [N]

L = length, [m]

i = current, amps [A]

B = magnetic field, tesla [T]

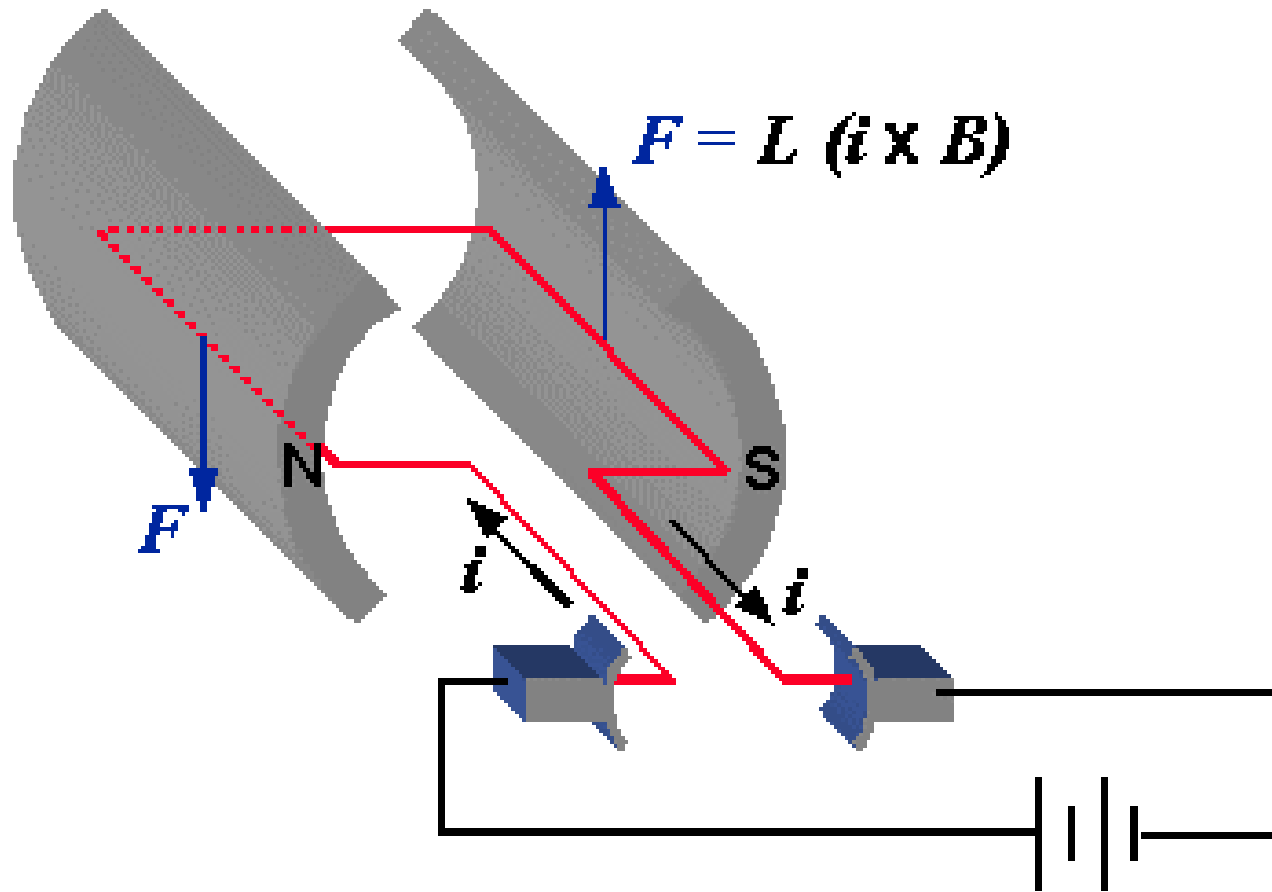

$$\tau = N A (i \times B)$$

A = area of coil

- Magnetic field may be generated by stator winding or by permanent magnet (PM)
- Poles is number of N-S pairs

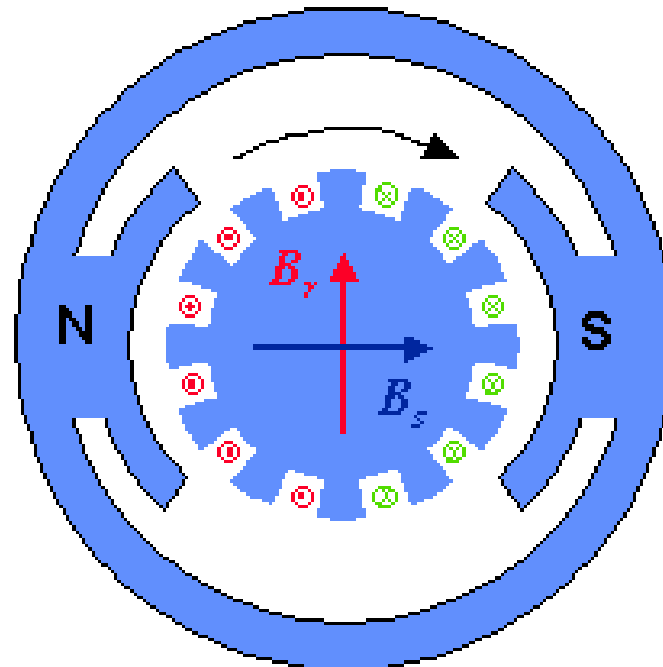

Motors have the capability to generate a voltage if they are mechanically rotated (acting as a generator). This is due to inductance. However, it should be noted that even if a motor is operated electrically, this generated voltage is still present! Its polarity will be opposite to the applied voltage, which has a counter-acting behavior that must be accounted for. We call this the *back-emf*, noted as e . Applying Kirchoff's law (voltage) to the circuit:

$$V = IR + e$$

This essentially says that the voltage applied to the motor (the battery, for example) must be equal to the *total* current through the circuit, I , times the circuit's resistance (R), plus the back-emf. In other words, Ohm's law is modified here to account for the fact that the back-emf is also part of our circuit.

We can depict our arrangement graphically:

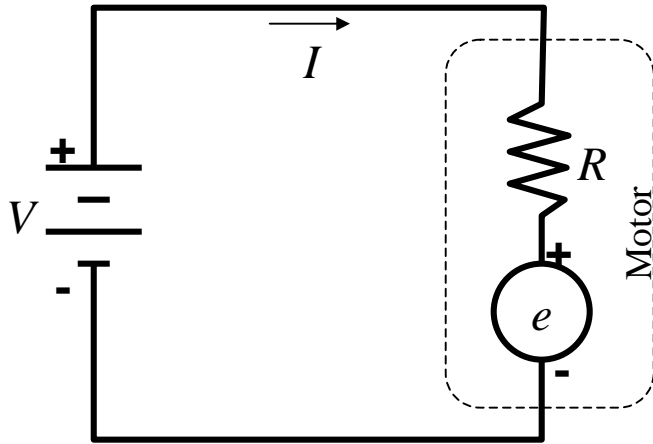

$$V = IR + e$$

When the motor is not rotating (starting, or stalled), the back-emf, e , is zero. This allows us to write the starting current, or stall current, I_s , as:

$$I_s = \frac{V}{R}$$

Units:

I Amperes
 R Ohms
 V Volts

When the motor is rotating, the back-emf that is generated is simply proportional to the rotation speed, ω . The constant of proportionality is the back-emf constant, k_e .

$$e = k_e \omega$$

Units:

e Volts
 k_e Volt·sec.
 ω radians/sec. (1/sec)

The applied voltage is now related to the current and the motor (armature) speed by

$$V = IR + k_e \omega$$

Recalling Lorentz' Law, the force on the motor's coils, F , acting at a distance r from the rotation axis, generates a torque, T , where

$$T = F \times r$$

Units:

T N·m

F Newtons (N)

r meters (m)

If you simplify this by combining the motors characteristics such as the magnet strength and the coil (wire) lengths, etc., you can simply say that the motor's torque is proportional to the current. The constant of proportionality is written as k_t , and called the *torque constant*.

$$T = k_t I$$

Units:

T N·m

k_t N·m/Amperes

I Amperes (A)

Re-arranging this (solve for I) and substituting into the earlier equation, we get

$$V = \frac{TR}{k_t} + k_e \omega$$

It turns out (see references for details) that provided the units are converted to a common form, then $k_t = k_e = k$. This simplifies our equation further.

$$V = \frac{TR}{k} + k\omega$$

This is re-arranged into other forms, which can be useful, depending on what you need to calculate:

$$\omega = -\frac{TR}{k^2} + \frac{V}{k}$$

$$T = \frac{k(V - k\omega)}{R}$$

and recalling
 $T = k_t I$, or $I = T / k_t = T / k$

$$I = \frac{(V - k\omega)}{R}$$

Motor Model

Analyzing the behavior of a DC motor

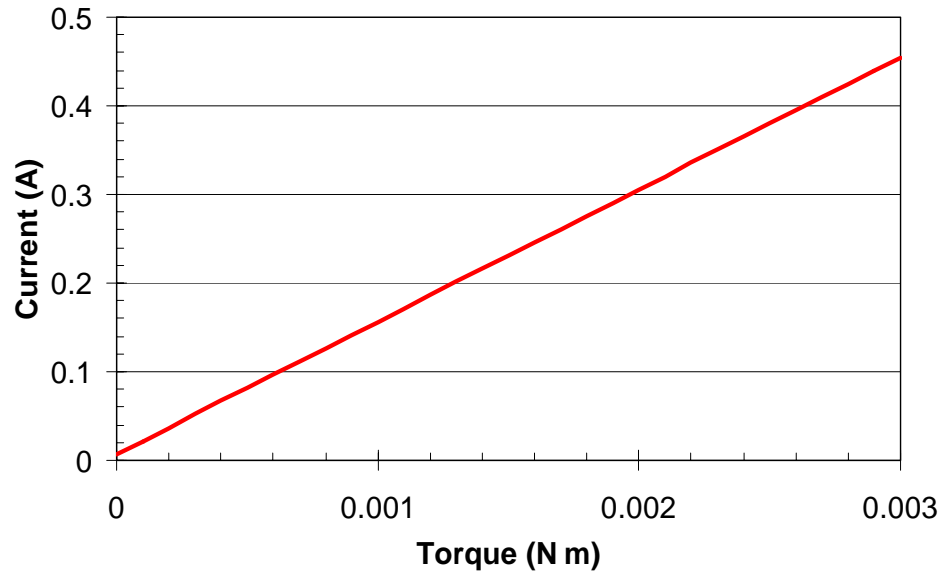

Parameters:

V 6 V

k_t 0.0067 N m/A

R 13.4 Ω

I_0 7 mA

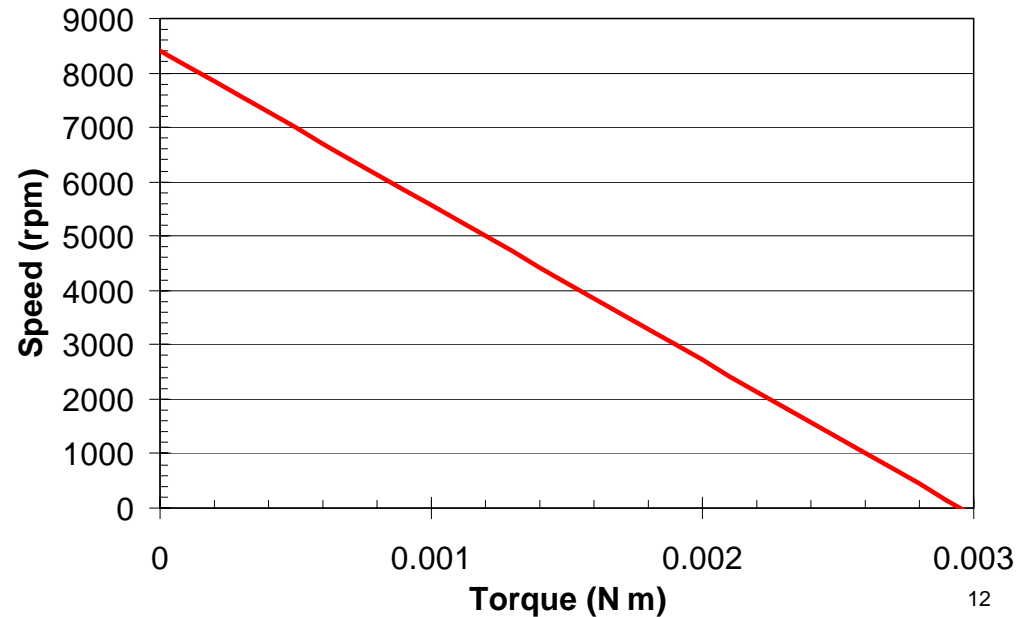

The mechanical power of a rotating shaft is written as the product of the torque and the rotational speed:

$$P_m = T\omega$$

Units:

T N·m

ω radians/sec (1/s)

P Watts (J/s)

It is useful here to comment on the units of energy and power. When it all breaks down, the units of energy (in metric units) are Joules (J). Power is a measure of energy per units time, or Joules/second, (J/s). This is a Watt.

$$1 \text{ Joule} = 1 \text{ kg} \frac{\text{meter}^2}{\text{second}^2} = 1 \text{ Newton} \cdot \text{meter}$$

$$1 \text{ Watt} = 1 \frac{\text{Joule}}{\text{second}} = 1 \frac{\text{Newton} \cdot \text{meter}}{\text{second}}$$

The electrical power of the motor is written as the product of the applied current and the voltage:

$$P_e = IV$$

Units:

I Amperes

V Volts

P Watts (J/s)

Notice that the units for power here are *also* written in watts. This is because

$$1 \text{ Watt} = 1 \text{ Volt} \cdot \text{Ampere} = 1 \text{ Volt} \frac{\text{Coulomb}}{\text{second}}$$

and

$$1 \text{ Joule} = 1 \text{ Coulomb} \cdot \text{Volt}$$

So, now we have some relationships that allow us to relate the mechanical characteristics with the electrical characteristics of a motor.

The mechanical power of the motor can now be expressed in terms of the operating conditions:

$$P_m = T\omega$$

$$P_m = -\left(\frac{R}{k^2}\right)T^2 + \frac{V}{k}T$$

Notice the quadratic nature of this equation

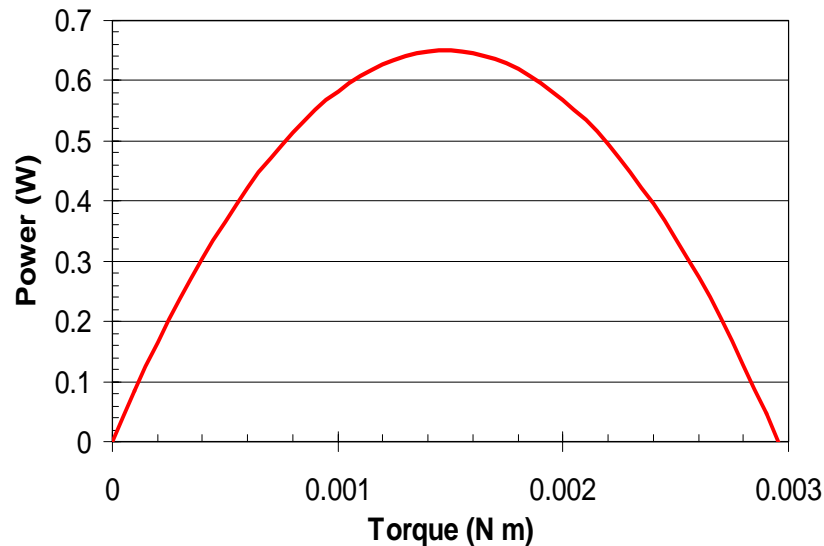

Parameters:

V	6 V
k_t	0.0067 N m/A
R	13.4 Ω
I_0	7 mA

The efficiency of the motor is the ratio of the mechanical power output divided by the electrical power input:

$$\eta = \frac{P_m}{P_e}$$

Notice the maximum power does not occur at the same torque as the maximum efficiency! (Nor is it at the maximum speed!)

Parameters:

V	6 V
k_t	0.0067 N m/A
R	13.4 Ω
I_0	7 mA

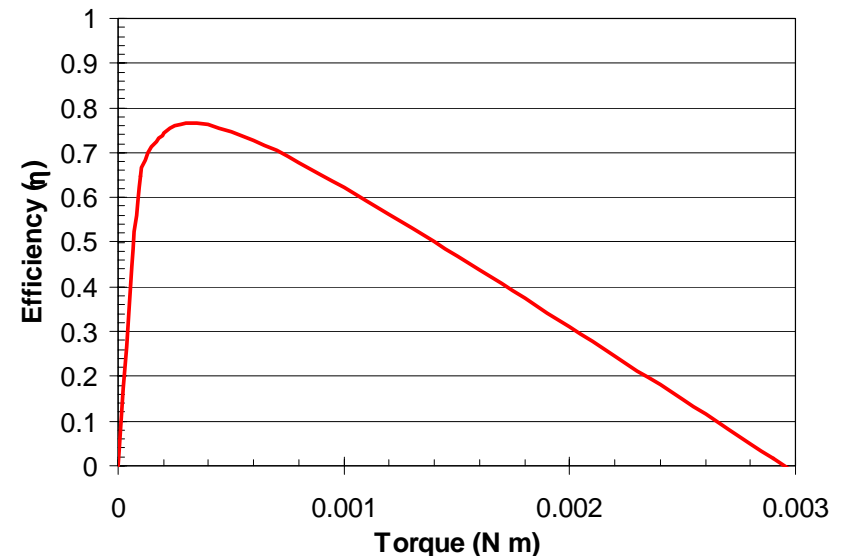
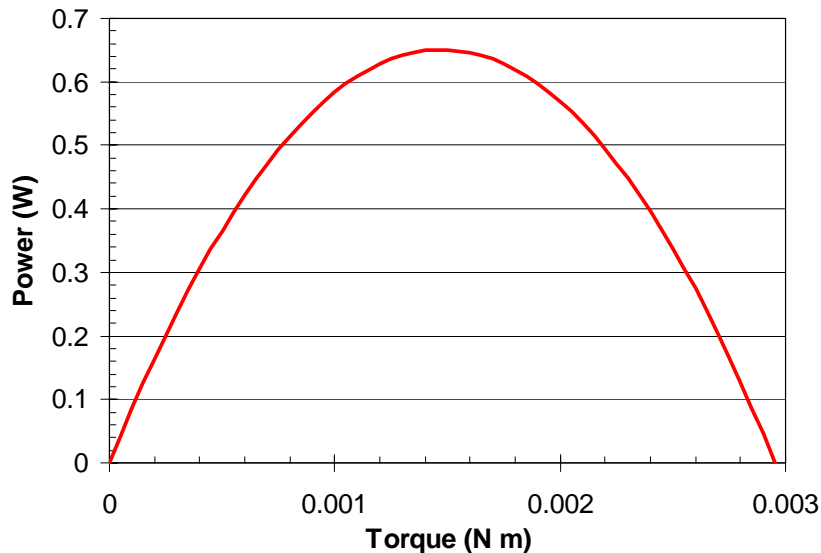

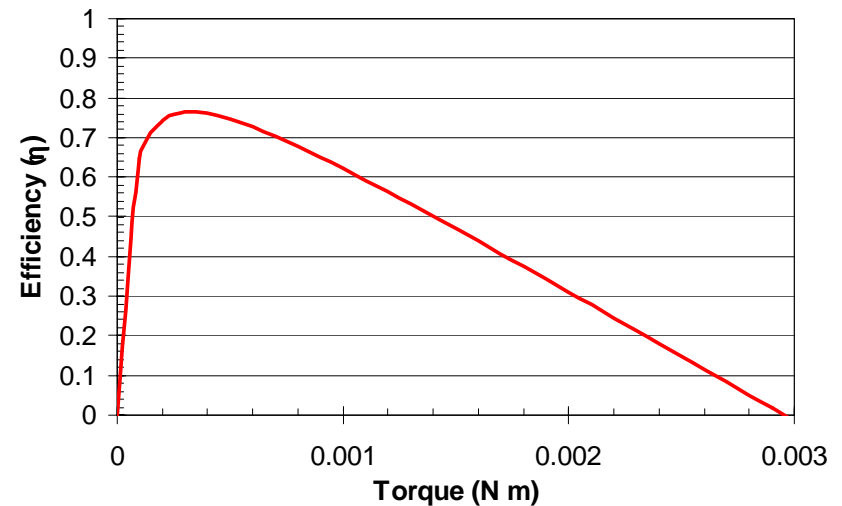
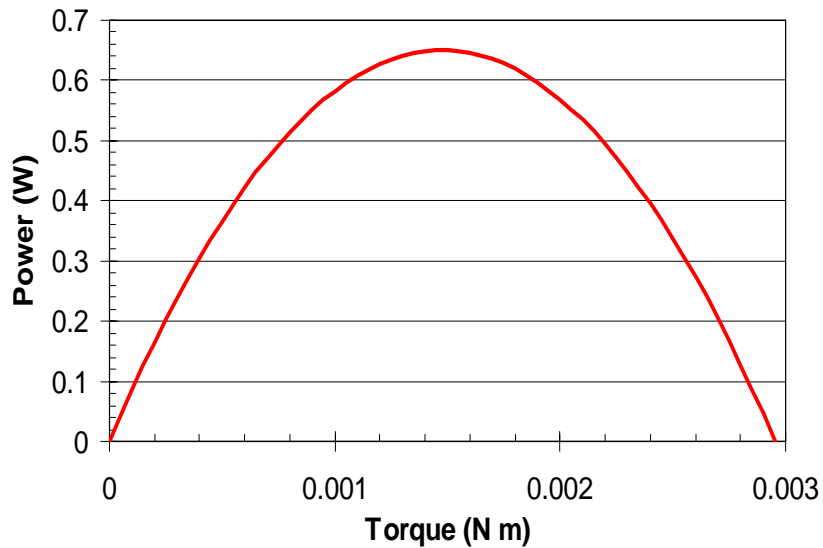
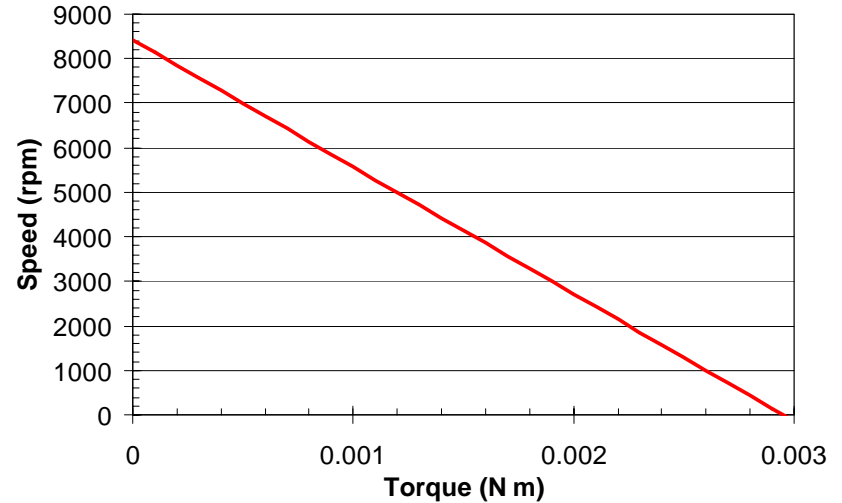
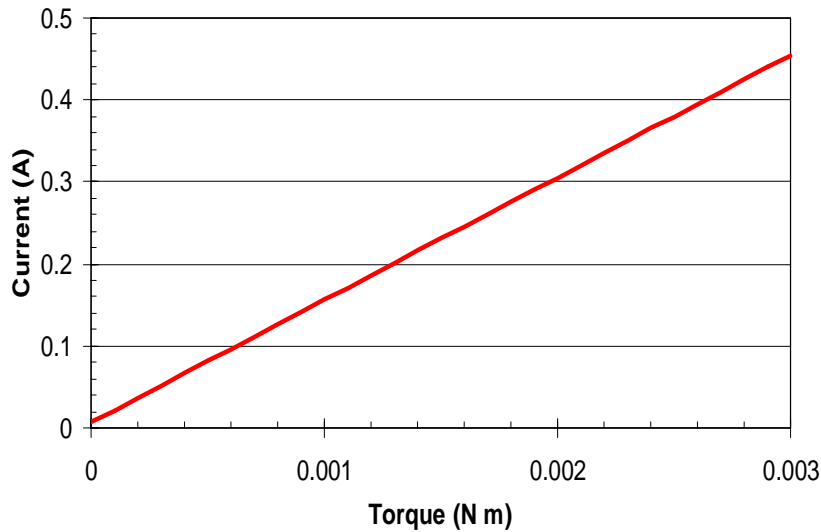

Parameters:

V	6 V
k_t	0.0067 N m/A
R	13.4 Ω
I_0	7 mA

Other convenient relationships:

$$I_0 = I_s - \frac{T_{\max}}{k_t}$$

$$P_{\max} = \frac{1}{4} \omega_{\max} T_{\max}$$

$$\eta_{\max} = \left(1 - \sqrt{\frac{I_0}{I_s}} \right)^2$$

$$@ T = \frac{T_{\max}}{2}$$

$$@ T = k_e \sqrt{I_0 I_s} = k_e \sqrt{I_s^2 - \frac{I_s T_{\max}}{k_t}}$$

Recall:

I_s Start (or Stall) Current

I_0 No-Load Current

T_{\max} Stall Torque

Example

Interpreting Motor Data

Manufacturers of motors usually provide data on the performance of the motor that can be used to construct the performance graphs that were illustrated on the previous pages. However, you will need to do some quick calculations to convert everything into a more useful format (units, etc.).

Inspection of the equations (for the graphs) presented earlier should reveal that you **need to know: V , T , R , k , and I_0** . All of the other parameters can be calculated from these. However, the manufacturer doesn't usually just give you these...**you need to take what they give you and calculate them yourself.**



RC-280RA/SA

OUTPUT: APPROX 0.5W-25W Carbon-brush motors

Typical Applications Household Appliances : Hair Clipper / Massager / Vibrator
Toys and Models : Motorized Toy / Radio Control Model

Jameco Part Number 177498

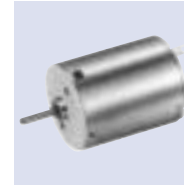

MODEL	VOLTAGE		NO LOAD		AT MAXIMUM EFFICIENCY					STALL		
	OPERATING RANGE	NOMINAL	SPEED	CURRENT	SPEED	CURRENT	TORQUE		OUTPUT	TORQUE		CURRENT
			r/min	A	r/min	A	mNm	g-cm	W	mNm	g-cm	A
RC-280RA-2865	4.5 - 6.0	4.5V CONSTANT	13600	0.27	11350	1.36	2.92	29.8	3.47	17.7	180	6.90
RC-280RA-20120	4.5 - 9.0	4.5V CONSTANT	7500	0.11	6110	0.48	1.91	19.4	1.22	10.3	105	2.13
		6V CONSTANT	9900	0.12	8210	0.58	2.26	23.0	1.94	13.2	135	2.82
RC-280RA-2485	4.5 - 8.4	7.2V CONSTANT	18800	0.21	14260	1.18	3.27	33.3	4.87	21.6	220	6.60
RC-280SA-2865	4.5 - 9.0	6V CONSTANT	14000	0.28	11910	1.60	4.46	45.5	5.56	29.9	305	9.10
RC-280SA-20120	4.5 - 12.0	6V CONSTANT	7700	0.12	6390	0.58	2.93	29.9	1.96	17.2	175	2.85
		12V CONSTANT	15500	0.15	13320	0.92	4.68	47.7	6.52	33.3	340	5.60
RC-280SA-2485	4.5 - 9.6	7.5 V CONSTANT	13300	0.19	11350	1.10	4.25	43.3	5.04	28.9	295	6.40

UNIT: MILLIMETERS

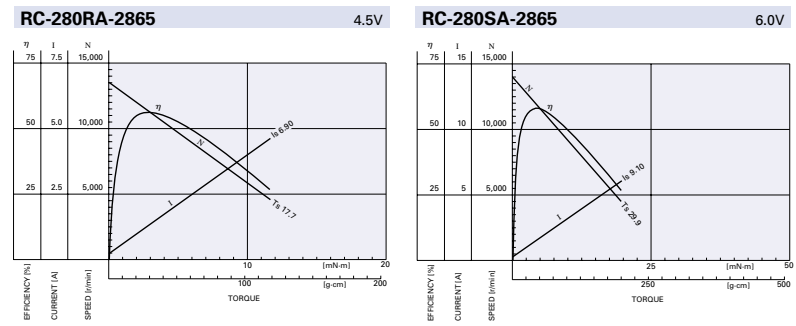
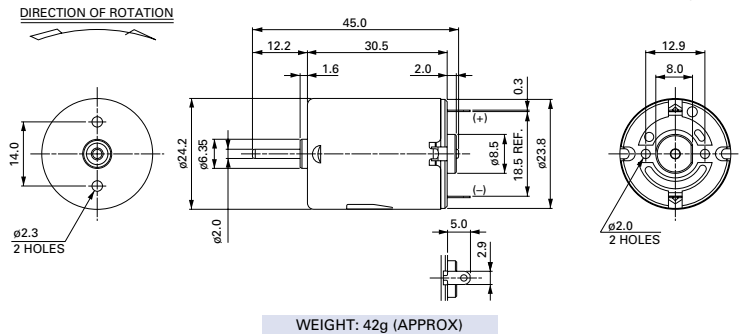

Example

Interpreting Motor Data

Different manufacturers tend to give you different data parameters. We will use this one (excerpted from previous page).

Jameco Part Number 177498 (\$1.75 each)

MODEL	VOLTAGE		NO LOAD		AT MAXIMUM EFFICIENCY					STALL		
	OPERATING RANGE	NOMINAL	SPEED	CURRENT	SPEED	CURRENT	TORQUE		OUTPUT	TORQUE		CURRENT
			RPM	A	RPM	A	mN-m	g-cm	W	mN-m	g-cm	A
RC-280RA-2865	4.5 ~ 6.0	4.5V CONSTANT	13600	0.27	11350	1.36	2.92	29.8	3.47	17.7	180	6.90
RC-280RA-20120	4.5 ~ 9.0	4.5V CONSTANT	7500	0.11	6110	0.48	1.91	19.4	1.22	10.3	105	2.13
		6V CONSTANT	9900	0.12	8210	0.58	2.26	23.0	1.94	13.2	135	2.82
RC280RA-2485	4.5 - 8.4	7.2V CONSTANT	16800	0.21	14260	1.18	3.27	33.3	4.87	21.6	220	6.6
RC-280SA-2865	4.5 ~ 9.0	6V CONSTANT	14000	0.28	11910	1.60	4.46	45.5	5.56	29.9	305	9.10
RC-280SA-20120	4.5 ~ 12.0	6V CONSTANT	7700	0.12	6390	0.58	2.93	29.9	1.96	17.2	175	2.85
		12V CONSTANT	15500	0.15	13320	0.92	4.68	47.7	6.52	33.3	340	5.60
RC-280SA-2485	4.5 ~ 9.6	7.5 V CONSTANT	13300	0.19	11350	1.10	4.25	43.3	5.04	28.9	295	6.40

Different manufacturers tend to give you different data parameters. We will use this one (excerpted from previous page).

Step 1: While the motor can be used at a range of voltages, the specifications they give are for the *Nominal voltage* of

$$V = 7.2\text{V}$$

Step 2: Calculate the torque constant k_t ($= k_e = k$) using T and I values at some known conditions. Since they give both at the stall condition, we can use these to calculate k .

$$T = k_t I \Rightarrow k_t = k = \frac{T}{I}$$

$$k = \frac{21.6 \times 10^{-3} \text{ N}\cdot\text{m}}{6.60 \text{ A}} = 3.27 \times 10^{-3} \frac{\text{N}\cdot\text{m}}{\text{A}} \Rightarrow k = 3.27 \times 10^{-3} \frac{\text{N}\cdot\text{m}}{\text{A}}$$

Step 3: Similarly, calculate the resistance, R , using T , ω , k , and I values at some known conditions. Again, the stall point ($\omega=0$) is used...

$$I = \frac{(V - k\omega)}{R} \Rightarrow R = \frac{(V - k\omega)}{I} = \frac{V}{I} \Big|_{stall}$$

$$R = \frac{7.2\text{V}}{6.60\text{A}} = 1.091\Omega$$

$$R = 1.091 \frac{\text{V}}{\text{A}} \Rightarrow R = 1.091 \Omega$$

Example

Interpreting Motor Data

Step 4: We now have all the parameters we need to develop some performance charts using our equation set.

Summary of Data :

$$V = 7.2\text{V}$$

$$I_0 = 0.21\text{A}$$

$$k = 3.27 \times 10^{-3} \frac{\text{N}\cdot\text{m}}{\text{A}}$$

$$R = 1.091 \Omega$$

$$I = \frac{(V - k\omega)}{R}$$

$$\omega = \frac{V}{k} - \frac{TR}{k^2}$$

$$P_e = IV$$

$$P_m = -\left(\frac{R}{k^2}\right)T^2 + \frac{V}{k}T$$

$$\eta = \frac{P_m}{P_e}$$

Example

Interpreting Motor Data

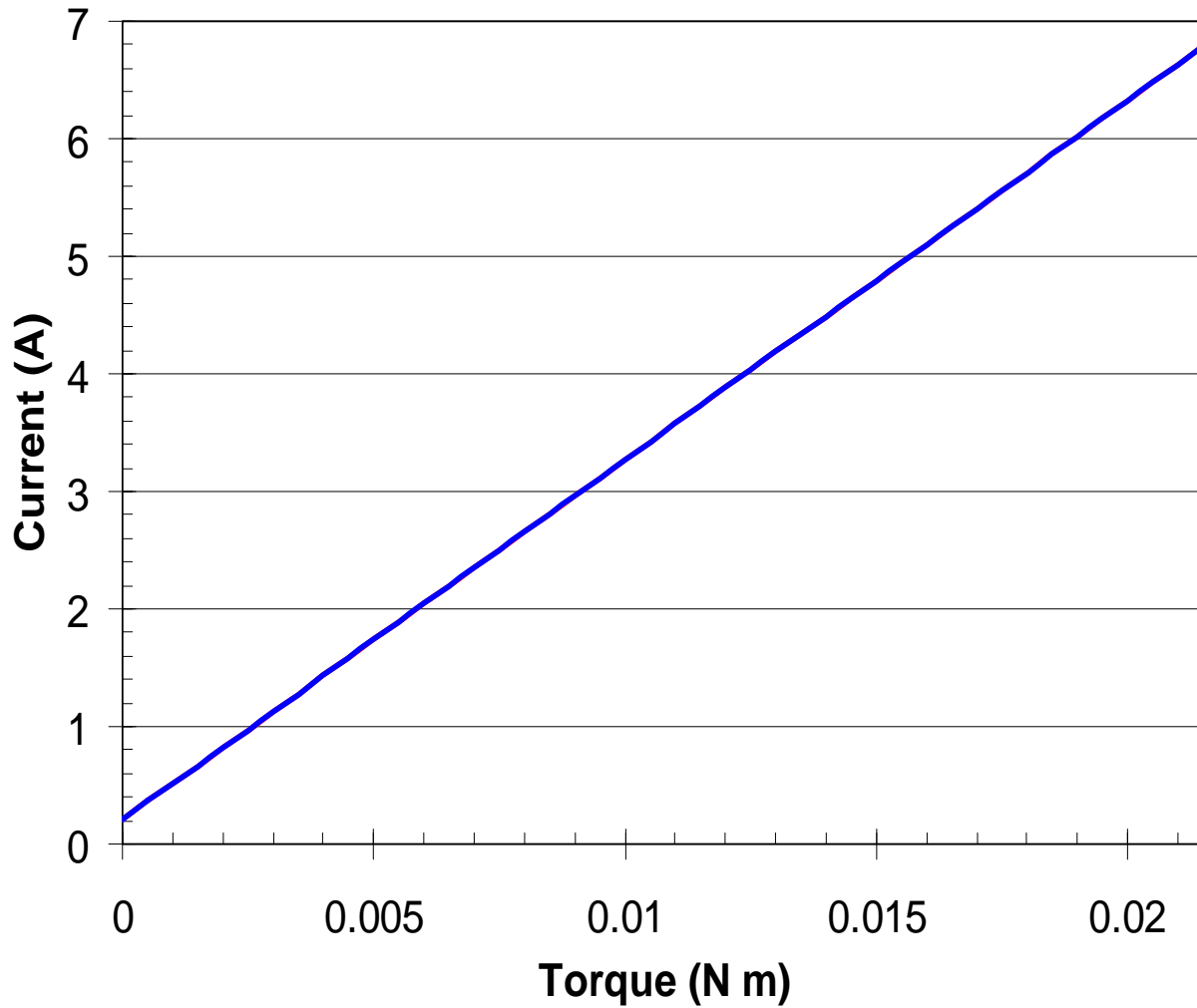

Parameters :

$$V = 7.2\text{V}$$

$$I_0 = 0.21\text{A}$$

$$k = 3.27 \times 10^{-3} \frac{\text{N}\cdot\text{m}}{\text{A}}$$

$$R = 1.091 \Omega$$

This plot holds for any value of V .

Example

Interpreting Motor Data

Voltage varying from 3-9V.

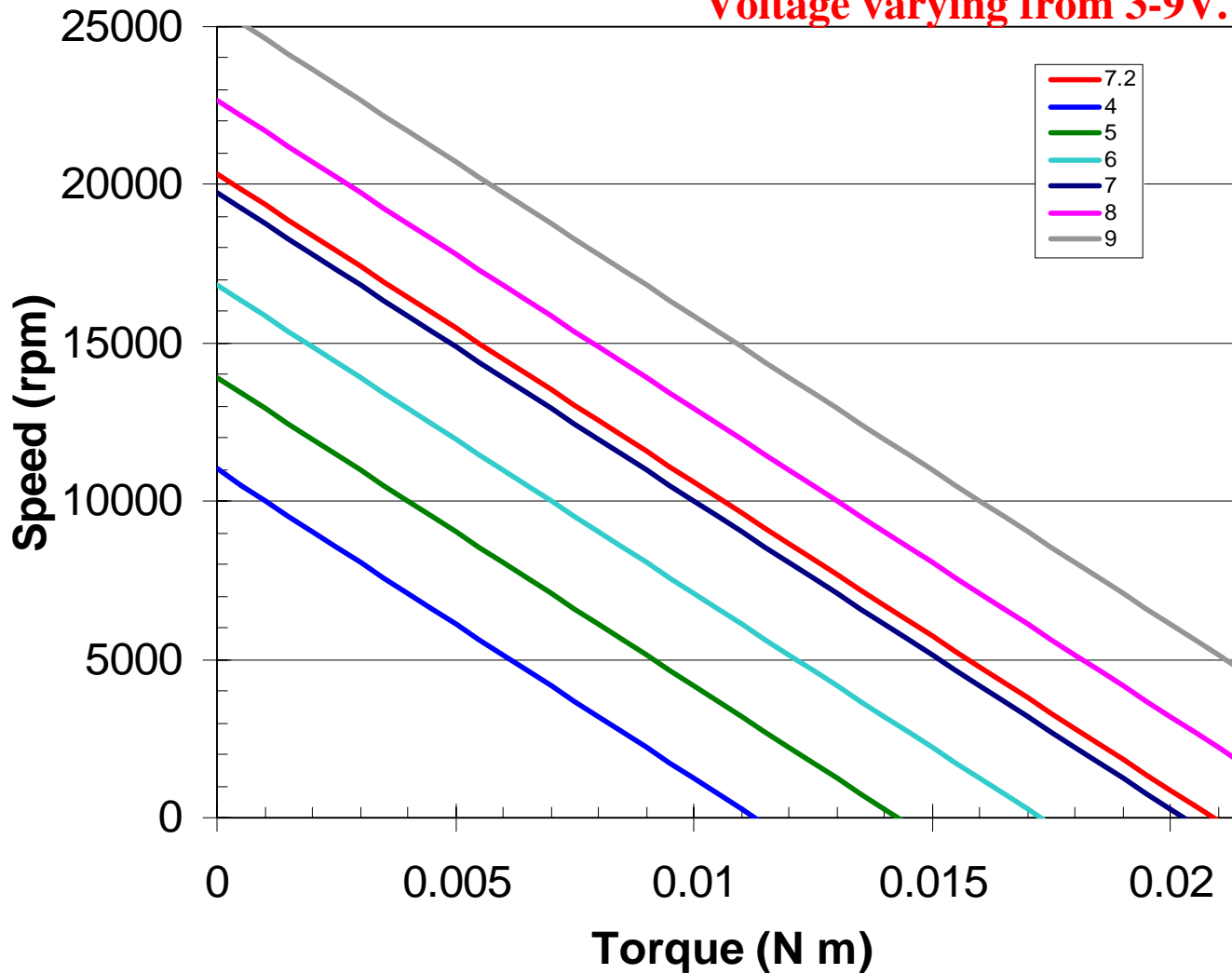

Parameters :

$$I_0 = 0.21A$$

$$k = 3.27 \times 10^{-3} \frac{N \cdot m}{A}$$

$$R = 1.091 \Omega$$

Example

Interpreting Motor Data

Voltage varying from 3-9V.

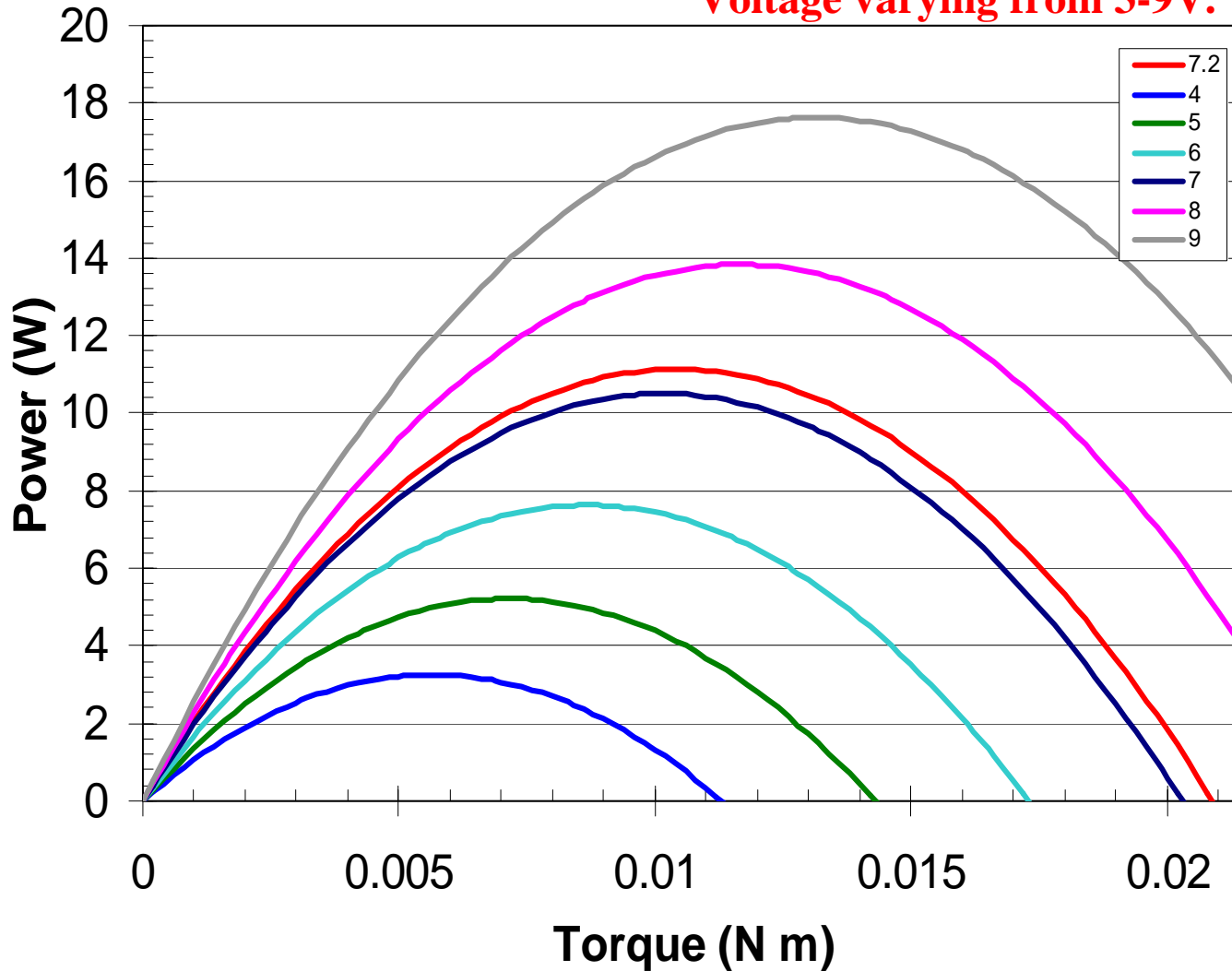

Parameters :

$$I_0 = 0.21\text{A}$$

$$k = 3.27 \times 10^{-3} \frac{\text{N}\cdot\text{m}}{\text{A}}$$

$$R = 1.091 \Omega$$

Example

Interpreting Motor Data

Voltage varying from 3-9V.

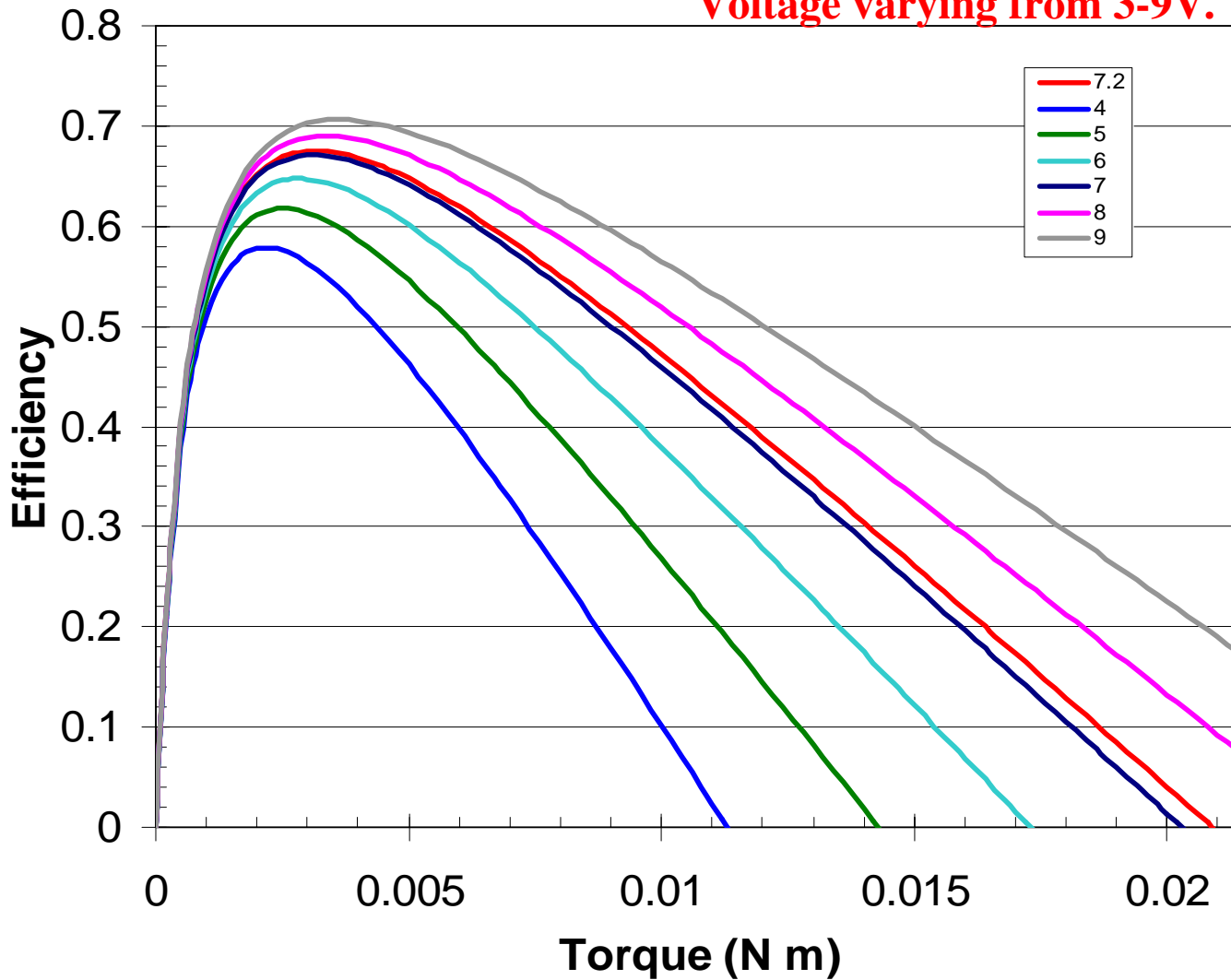

Parameters :
 $I_0 = 0.21\text{A}$
 $k = 3.27 \times 10^{-3} \frac{\text{N}\cdot\text{m}}{\text{A}}$
 $R = 1.091 \Omega$

Example

Interpreting Motor Data

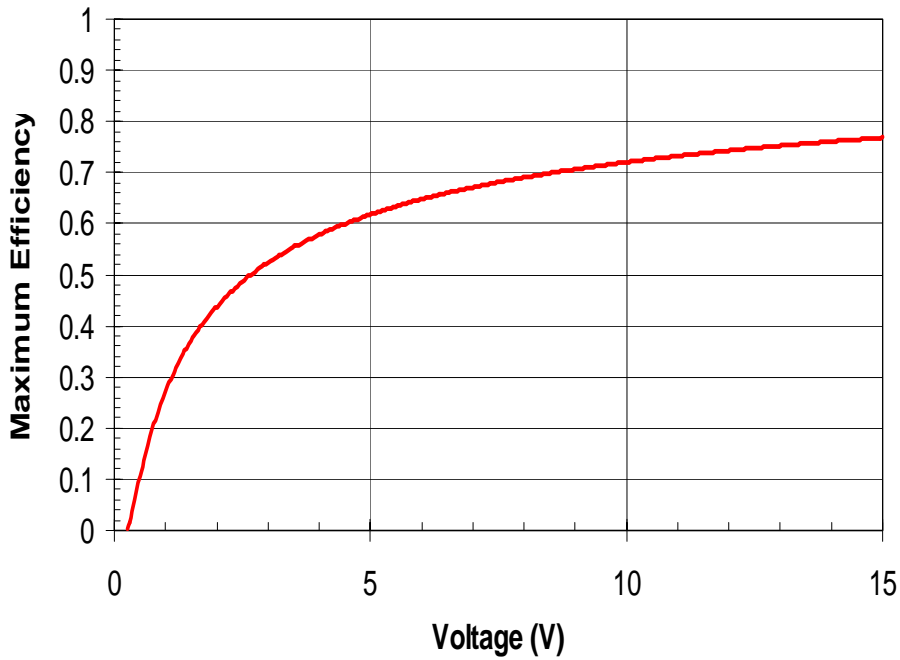

Parameters :
 $I_0 = 0.21\text{A}$
 $k = 3.27 \times 10^{-3} \frac{\text{N}\cdot\text{m}}{\text{A}}$
 $R = 1.091 \Omega$

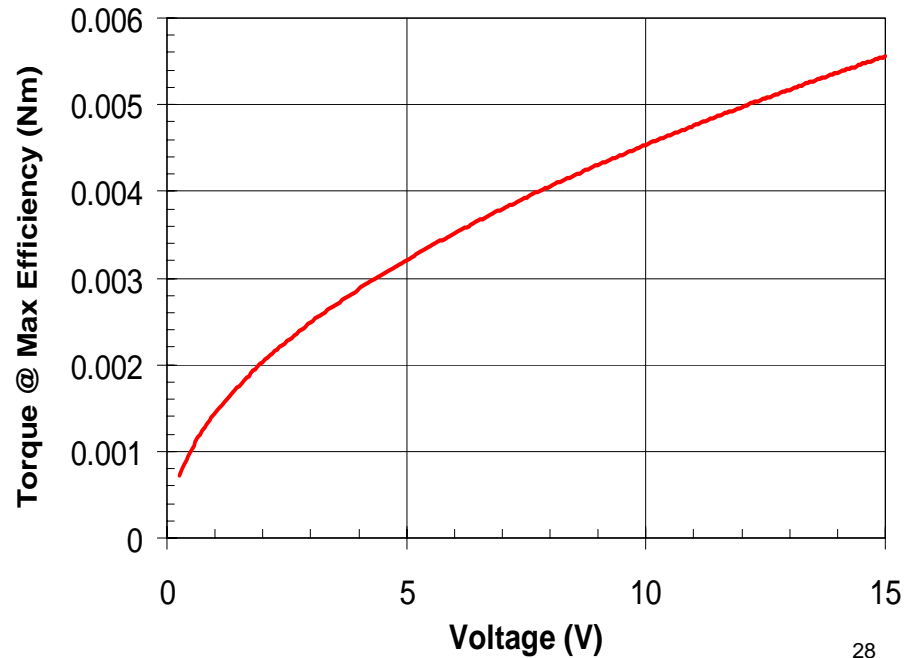

There are a few ways to alter the output shaft speed of a motor:

1. Run the motor at a different voltage. This causes the motor to slow for all torque values (see earlier plots).
2. Apply the voltage in pulses (more on this later).
3. Gear the motor. This causes the motor speed to *decrease* by the gear ratio G , but it also *increases* the torque by the same factor G .

Incorporating a gearing system, the motor can either be geared up or geared down to better match the motor ω with the desired shaft speed (such as for wheels).

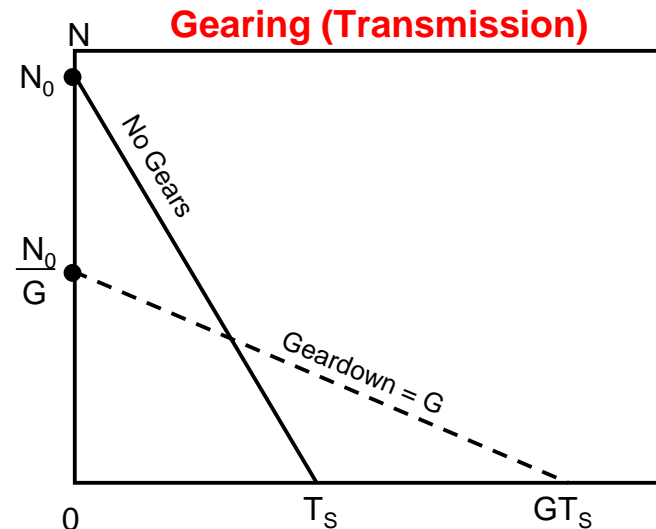
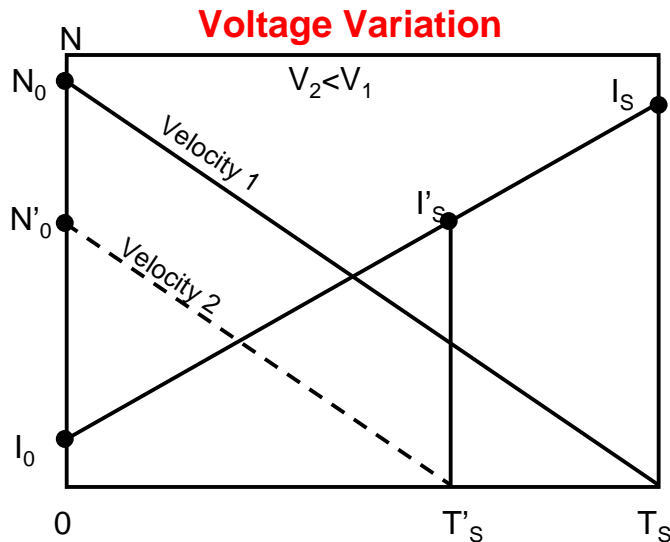

If A , B , C , and D represent the number of teeth on each gear in the figure, then the speed (or Torque) of the output shaft is related to the speed (or Torque) of the input shaft by:

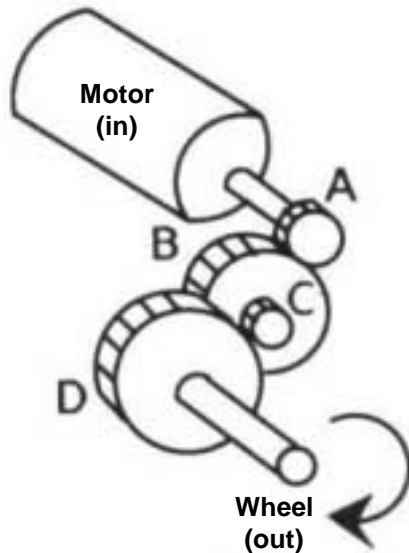

$$\omega_{out} = \frac{A C}{B D} \omega_{in}$$

$$T_{out} = \frac{B D}{A C} T_{in}$$

In practice, you will be able to design the transmission (A , B , C , and D) to provide the desired vehicle speed at a torque level that is close to the motor's peak efficiency.

For example:

With the previous motor's data, 6 volts produces a maximum efficiency of ~65% at a torque of ~0.0028 Nm. This torque, T_{in} , in turn, corresponded to a shaft speed, ω_{in} of ~14,000 rpm.

If our vehicle has 3" diameter wheels and we want it to travel at 10 mph, this requires a wheel shaft speed of:

$$\omega_{out} = \frac{10 \frac{\text{miles}}{\text{hr}} \cdot 63,360 \frac{\text{in}}{\text{mile}} \cdot 0.0166 \frac{\text{hr}}{\text{min}}}{\left(\pi \cdot 3 \frac{\text{in}}{\text{rev}}\right)} = 1,120 \text{ rpm}$$

To match this to the ideal motor shaft speed, the gear ratio, G would be:

$$G = \frac{A}{B} \frac{C}{D}, \text{ and thus, } \omega_{out} = G \omega_{in}, \text{ or, } G = \frac{\omega_{out}}{\omega_{in}}$$

To operate at maximum efficiency, the required gear ratio is G , and T_{out} is:

$$G = \frac{\omega_{out}}{\omega_{in}} = \frac{1,120 \text{ rpm}}{14,000 \text{ rpm}} = 0.08, \text{ (or 1:12.5)}$$

$$T_{out} = \frac{1}{G} T_{in} = \frac{1}{0.08} \cdot 0.0028 \text{ N} \cdot \text{m} = 0.0035 \text{ N} \cdot \text{m}$$

Pulse Width Modulation

In practice, it is necessary to control the speed of motors. Adjusting the voltage isn't always possible (batteries aren't adjustable), and some forms of voltage regulation simply waste the extra electricity, which is bad for efficiency.

Pulse Width Modulation keeps the voltage amplitude at the same level, it just shuts it off for a fraction of the time, creating a *time-averaged voltage* that can vary between 0-100% of the supplied voltage.

$$V_{ave} = V_{applied} \cdot PWR$$

$$PWR = \text{Pulse Width Ratio} = \frac{t_{on}}{t_{period}}$$

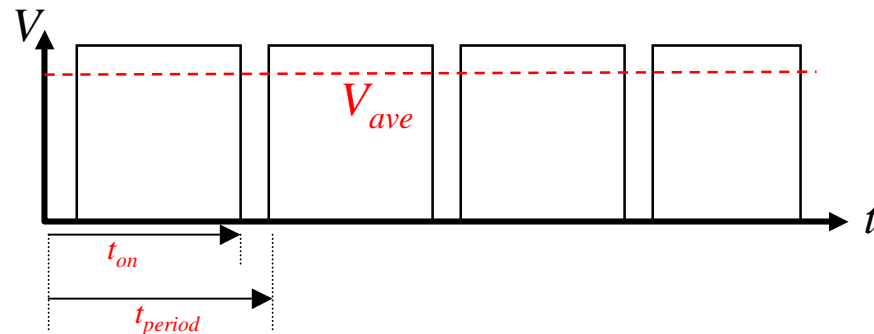
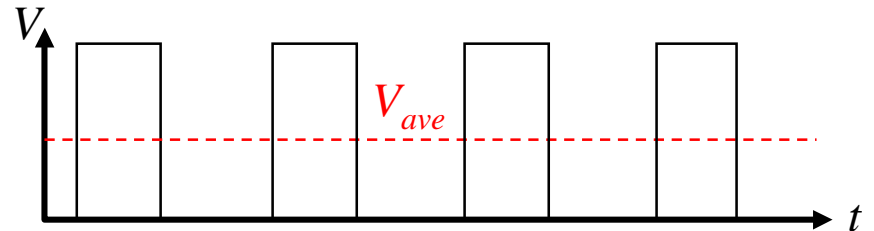
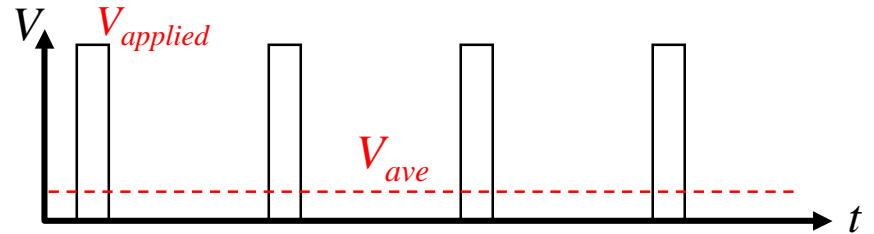

Servo Motors

NOTE: This is very different from Pulse Width Modulation, which is used for speed control.

Servo motors are distinctly different than the other motors we have talked about so far. They don't just keep rotating in circles. They move to a particular angular position and stay there.

They "know" where they are at any point in time (angle-wise) and thus can figure out if they need to keep rotating. This system needs two key parts:

1. A method for telling the motor what position to rotate to (*Pulse Width Modulation*).
2. A method for determining what position it currently is in (*potentiometer*).

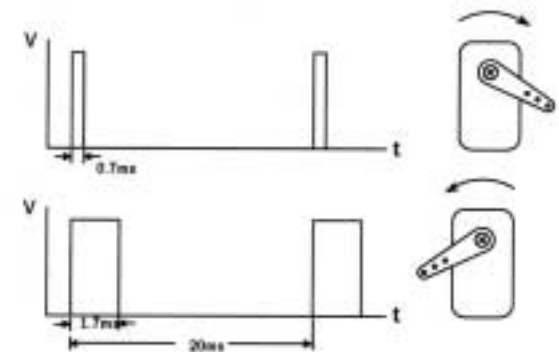
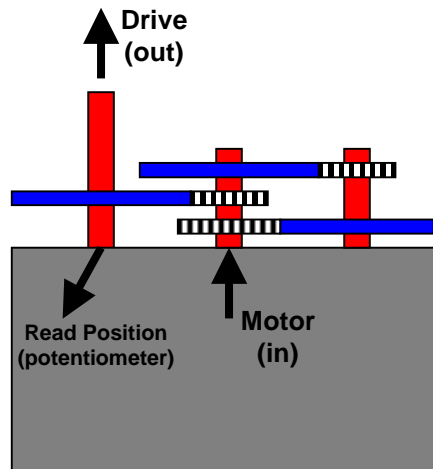

Pulse-Code Signals

Other Resources:

- *Mobile Robots* by Joseph Jones, Anita Flynn, and Bruce Seiger, 1999, Natick, MA, Chapter 7 (ISBN 1-56881-097-0)
- Carnegie Mellon University: DC Permanent Magnet Motors Lecture Notes: <http://www.ece.cmu.edu/~ece778/lecture-notes/Motor-lecture/>

NOTE: These resources will be useful for a more thorough description of motors.

The book is especially good for details on *Pulse Width Modulation* and *Pulse Code Modulation*.